

Unlike conventional lathes, escomatic lathes are based on a unique concept. The material, which is coil stock or bar, does not rotate. The cutting tools mounted onto the spinning tool head rotate around the material. This concept equally qualified for the manufacturing of small, medium and large lot size parts, contributes to the extremely high performance and cost savings achieved with escomatic machines.

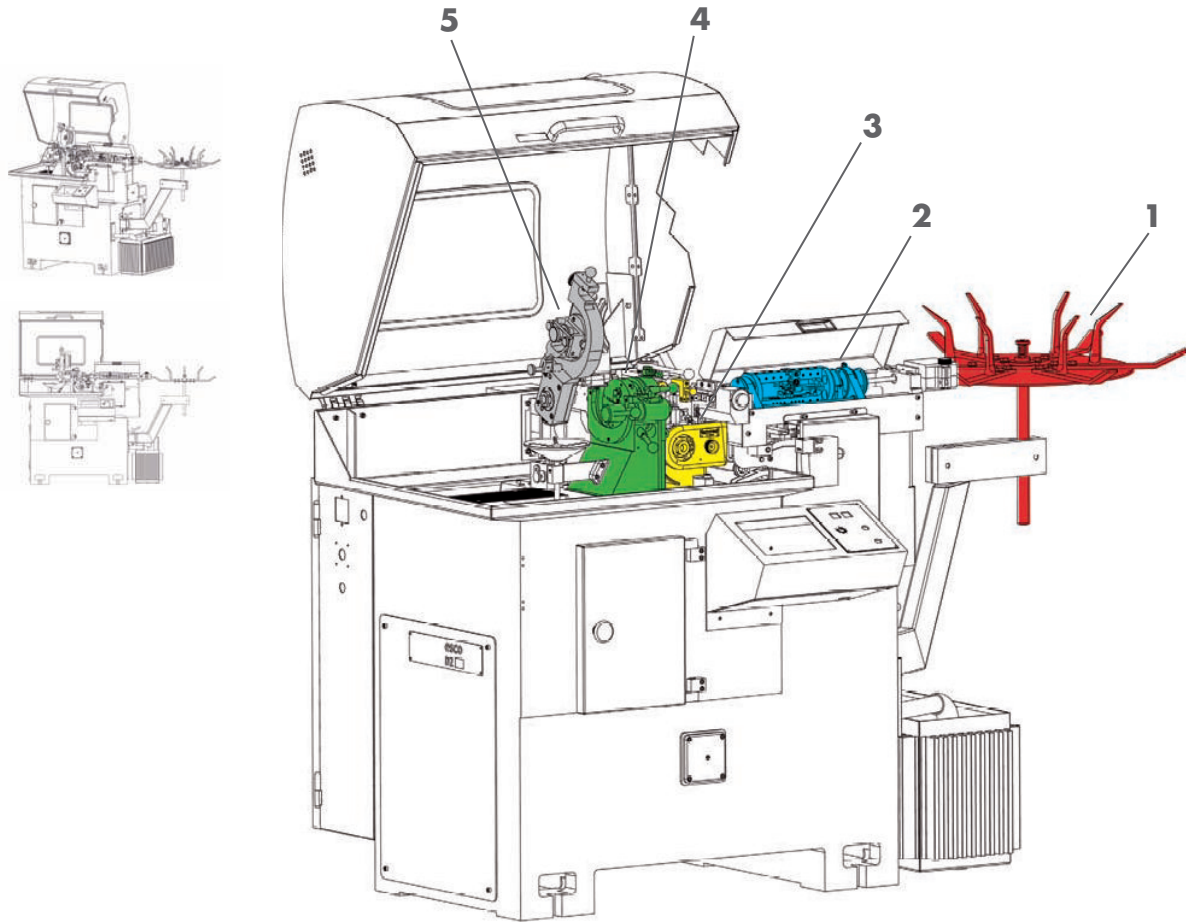

Examples:

Scale in millimetre.

